

Preparation of alumina and alumina–silica powders by wire explosion resulting from electric discharge

M. UMAKOSHI, T. YOSHITOMI

Department of Materials Science and Metallurgical Engineering, Kurume National College of Technology, 1232 Komorino-machi, Kurume, Fukuoka 830, Japan

A. KATO

Department of Chemical Science and Technology, Faculty of Engineering, Kyushu University, 6-10-1 Hakozaki, Higashi-ku, Fukuoka 812, Japan

Wires of aluminium and aluminium–silicon alloys containing 5.2 and 12.1 wt % Si were exploded in air by electric discharge, and the properties of the powders obtained were examined. The powders consisted of large particles of several micrometres and very fine spherical ones, which were formed from the metallic droplets and vapours, respectively, and were mostly oxidized. The large particles decreased with an increase in the charged energy. Although the particle-size distribution was broad, the average particle sizes were small and were increased from 0.7 μm to 1.3 μm with an increase in the charged energy. These powders were identified as γ -alumina, amorphous alumina–silica compound and a small amount of the metal. The amorphous phase crystallized to mullite in the temperature range 1153–1243 K, and the crystallization temperature fell with increase in the charged energy because the amount of fine particles formed from the vapours increased.

1. Introduction

The wire explosion method has been already applied to thermal spraying and press-forming techniques [1, 2]. A metal or alloy wire is exploded by passing a great impulse of current through it in this method. The wire can be heated to its boiling point and be partially vapourized because enormously high energy is generated due to electric discharge. It is expected that fine metallic or ceramic particles can be synthesized when the metallic droplets and vapours formed are rapidly condensed and/or react with ambient gases. Taking this possibility into consideration, Kase *et al.* [3, 4] tried to synthesize metallic particles and discussed the conditions for synthesizing ultrafine particles. We [5] have also studied the preparation of TiO_2 particles.

This paper reports the results of an investigation on the preparation of fine metallic and ceramic powders by the wire explosion method. An attempt was made to prepare fine alumina and alumina–silica powders by the explosion of aluminium and aluminium–silicon alloy wires in air, and to evaluate the properties of the powders. Alumina and alumina–silica ceramics are commonplace ones which are used in many fields of industry and there are various methods by which their powders are prepared.

2. Mechanism of wire explosion

The mechanism of wire explosion is schematically shown in Fig. 1 and is qualitatively described as follows [6]. With a wire placed between electrodes, the

wire is heated first by Joule's heat accompanied by the electric discharge and then melts. Because ambient air cools the surface of the wire, the high temperature inside produces metallic vapours, the formation of which causes the molten wire to break into droplets. The electric discharge takes place between droplets so that they are partly vapourized, and subject to further electric dissociation because the vapours undergo electric dissociation. The metallic vapours are instantaneously bound due to the pinch effect and inertia, and the expansion force thereby restricted causes a very high pressure. The rapid expansion of the high pressure vapours causes the wire to explode, producing shock waves, and at the same time metallic droplets and vapours are scattered at a high speed. The expansion duration is as short as several tens of microseconds which means that the particles formed are cooled at a great speed. In the case of a tungsten wire, it takes the order of 10^{-8} s for metallic droplets which are heated almost to boiling point to be solidified by collision with a mild steel substrate [7].

The main processing parameters of the explosion equipment are charged voltage, condenser capacity and discharging circuit frequency. In the case of thermal spraying, the parameters are optimized in terms of wire cross-sectional area and length [6]. Under the most suitable conditions, the electric discharge of charged energy appears nearly complete, with little residual electric charge left. Herein, it is calculated that the wire temperature rises to its boiling point, causing about 30% of the wire to be vaporized, which is in

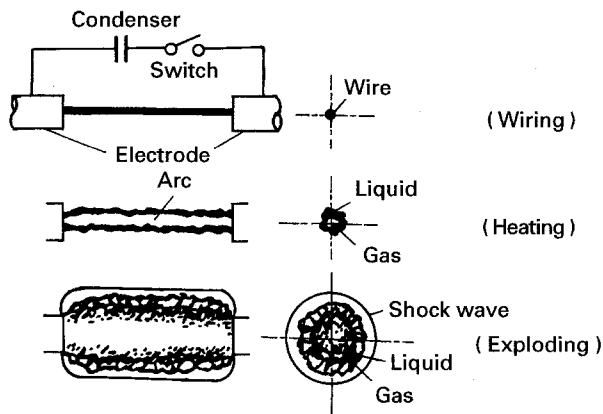

Figure 1 Mechanism of wire explosion resulting from electric discharge.

reasonable agreement with the values estimated by determining the charged energy from discharge current waveforms of various wire materials [6]. It is, therefore, predicted that increasing the charged energy will further increase the percentage of metallic vapours produced.

The present study has set the wire diameter and length as well as charged voltage so that a greater energy can be obtained than the above, by standardizing the optimum thermal spraying conditions, taking the prediction described above into consideration. The wire could be estimated to be vaporized from 30%–100% under the conditions which were specified in order to examine the particle size of the powders and to produce the finer powders.

3. Experimental procedure

3.1. Wire specimens

Three kinds of metallic wire specimens were available for exploding: aluminium (diameter 0.5 mm), and aluminium–silicon alloy containing 5.2 wt % Si (diameter 1.6 mm) and 12.1 wt % Si (eutectic composition, diameters 0.5 and 1.0 mm). The aluminium wire (Nilaco Co. Ltd) was more than 99.99 wt % purity, and the alloy wires (Nice Co. Ltd), which were put on the market for MIG welding, contained less than 0.1 wt % impurities such as iron, magnesium etc. They were cut into 55 mm lengths and cleaned with acetone.

3.2. Preparation of fine powders and evaluation of their properties

The basic circuit of the explosion apparatus (Nippon Tungsten Co. Ltd) is shown in Fig. 2. A wire was put on the electrodes, and the electric discharge was trig-

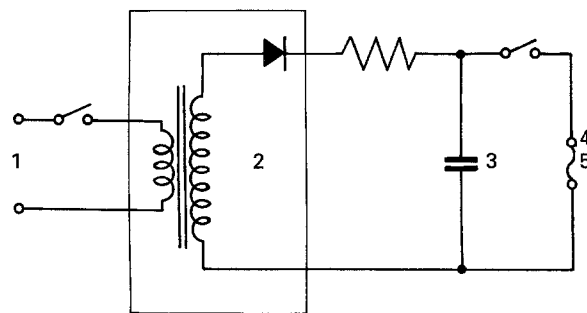

Figure 2 Circuit diagram of the electric discharge. (1) Electric source, (2) charger, (3) condenser, (4) electrode, (5) wire.

gered at the moment the electric charge was finished. At the same time, when the particles were formed by wire explosion and reacted with air, the powder was collected on filter paper for 1 min by means of a vacuum cleaner. The operation was repeated for the prescribed number of wires. The apparatus employs a 0–10 kV charged voltage and a constant capacitance of the condenser of 80 μ F. Consequently, the charged energy ranges from 0–4000 J [5].

The conditions of wire explosion are summarized in Table I. Herein, the concept of the energy ratio was introduced as a parameter controlling the powder properties on the assumption that the charged energy could be completely given off and the discharged energy could be completely converted into heat. It was defined as the ratio of heat contents required to melt and vaporize a wire at boiling point against the charged energy. The values of heat contents were estimated by using standard thermodynamic data such as heat capacity, heat of fusion and heat of vapourization [8].

The particle morphology of the powders collected on filter paper was observed by scanning electron microscopy (SEM) and transmission electron microscopy (TEM), and the powders were identified by the powder X-ray diffraction (XRD) using CuK_α radiation and infrared spectroscopy (IR). The particle-size distribution was also measured by the centrifugal sedimentation method, and thermogravimetric – differential thermal analysis (TG–DTA) was carried out.

4. Results and discussion

4.1. Particle morphology and size of the prepared powders

The yield rate of the powder trapped on filter paper ranged from 50%–70% of the wire's weight, chiefly depending on the energy ratio. The colour of the powders obtained was white or light grey.

TABLE I The conditions of wire explosion

Wire	Diameter (mm)	Impurity (wt %)	Charged voltage (kV)	Energy ratio
Aluminium	0.5	< 0.01	2.0–9.0	0.43–8.8
Al–5.2 wt % Si	1.6	< 0.1	7.0–9.5	0.51–0.95
Al–12.1 wt % Si	0.5	< 0.1	1.5–9.0	0.24–8.5
	1.0		3.5–9.5	0.32–2.4

Figs 3 and 4 show examples of the particle shape and size of the powders formed by wire explosion. It can be seen that the powder consists of comparatively large particles of several micrometres and very fine ones. In the large particles, shrinkage cavities, and roundish and irregular particles are seen in the scanning electron micrograph. Hence, it is suggested that these particles are formed from the droplets. The irregularity of the particles seems to be caused by the formation of the dense and hard oxidized layer on the droplet and collision of the flying particles with the wall of the working vessel. The large particles tended to decrease with increase in the energy ratio and, moreover, all large particles could not be trapped on the filter paper.

The dependence of the yield rate on the energy ratio may possibly be attributed to this observation. It was also observed by SEM that the number of large particles in the case of the aluminium wire explosion was smaller than in the case of the alloy wire explosion. TEM showed the fine particles to be almost spherical

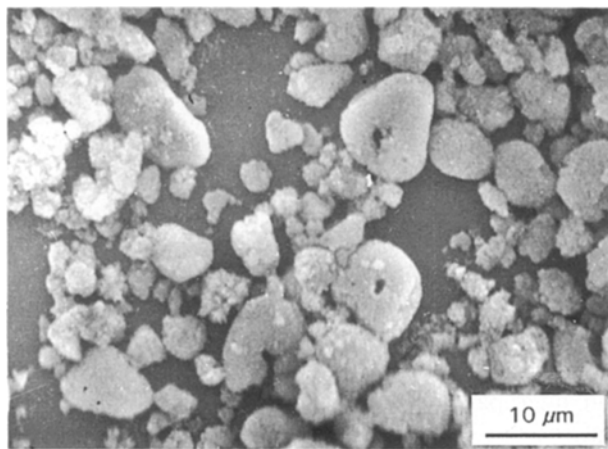

Figure 3 Scanning electron micrograph of large particles formed from metallic droplets. Wire, Al-12.1 wt % Si (diameter 1.0 mm); charged voltage, 6.5 kV.

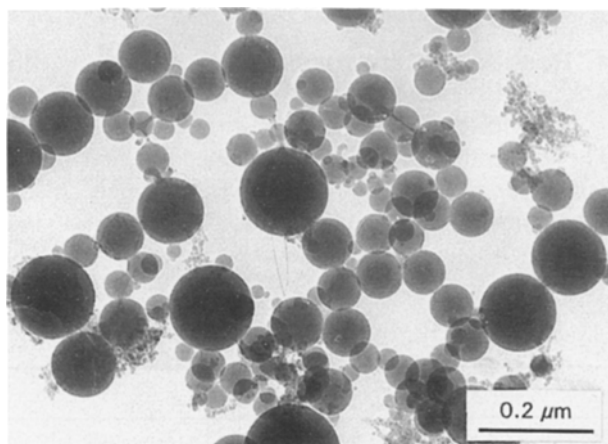

Figure 4 Transmission electron micrograph of fine particles formed from metallic vapours. Wire, Al-12.1 wt % Si (diameter 1.0 mm); charged voltage, 7.5 kV.

and less than 0.2 μm diameter though the particle size was widely distributed. It can be expected that the fine particles are mainly formed from oxidation of the condensed metallic vapours. In addition, the morphologies of large and fine particles did not depend on the kind of wire nor the charged voltage. Particle-size distribution was broad because the large and fine particles coexisted in every powder as observed by SEM. This was consistent with the previous work [5] and was taken as one of the characteristics of the wire explosion method. However, the average particle size of the powder obtained from the aluminium wire was small and increased from 0.7 μm to 1.3 μm with increasing energy ratio. The average particle size of the alumina powder was appreciably smaller than that of the alumina-silica powders. The reason is probably that the much more Joule's heat generated by the electric discharge can be supplied to the aluminium wire compared with the case of aluminium-silicon wires because of the great difference in electrical conductivity between aluminium and the alloys.

4.2. Phases formed from the powders prepared by wire explosion

The X-ray diffraction patterns of powders which have been formed at the nearly equal energy ratio of about unity are illustrated in Fig. 5. The main XRD peaks were analysed to be attributable to so-called γ -alumina, which could not be exactly classified into η , γ or δ phase. It was, of course, found that their peak intensity decreases as the silicon content in the wire becomes higher. A small amount of aluminium was also detected in some cases. This could be due to the incomplete oxidation of large particles. The XRD (440) peak intensities of γ -alumina are plotted against the energy ratio in Fig. 6. In the alloy wires employed for explosion, it can be observed that the peak intensity reduces with an increase in the energy ratio at the lower energy ratio, and is approximately constant at an energy ratio above unity. The contrary dependence is recognized in the case of the aluminium wire explosion, as seen in Fig. 6. It has been concluded in previous works [5, 9] that the amount of metallic vapour generated by wire explosion increases rapidly with increasing energy ratio up to about unity, but remains constant when the ratio exceeds unity. Consequently, the average size of particles becomes finer with increasing energy ratio at lower charged energies and then does not change so much at higher charged energies. It follows from this evidence that the reduction of γ -alumina peak intensity of the alumina-silica powders is caused by promoting oxidation of silicon in the wire and forming an amorphous alumina-silica compound, whereas the increment in the case of the alumina powder is caused by raising the degree of crystallization.

Fig. 7 shows the IR absorption spectra of the same powders as used for the measurement of XRD patterns illustrated in Fig. 5. It is found that the IR absorption spectrum of every powder is broad, and therefore the degree of crystallization is not good. The strong IR absorption peak at the wave number of

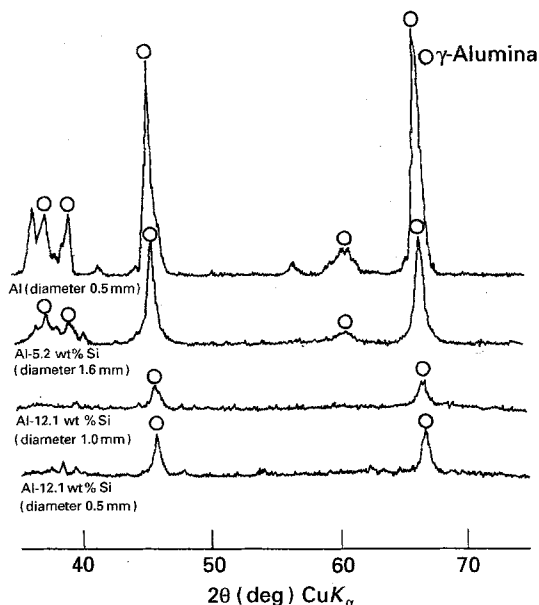

Figure 5 X-ray diffraction patterns of alumina and alumina-silica powders prepared by wire explosion at the nearly equal energy ratio of about unity.

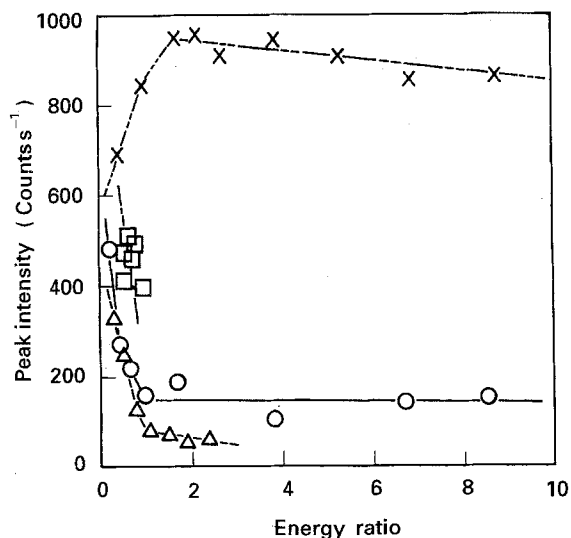

Figure 6 Relationship between the XRD (440) peak intensity of γ -alumina in the powders prepared by wire explosion, and the energy ratio. (○) Al-12.1 wt % Si, diameter 0.5 mm; (△) Al-12.1 wt % Si, diameter 1.0 mm; (□) Al-5.2 wt % Si, diameter 1.6 mm; (×) Al, diameter 0.5 mm.

about 800 cm^{-1} can be attributed to the AlO_4 tetrahedron [10], which supports the formation of spinel-type γ -alumina. The weak IR absorption peak at the wave number of about 1100 cm^{-1} is also observed in the alumina-silica powders and is presumed to be due to stretching vibration of Si-O bonding [10]. The broadness of its peak indicates the formation of an amorphous or imperfectly crystallized alumina-silica compound followed by oxidation of silicon in the wire. Incidentally, the chemical composition of alumina-silica powders may not change with the energy ratio because the boiling points of aluminium and silicon are not so different from each other, though the melting point of aluminium is much lower than that of silicon.

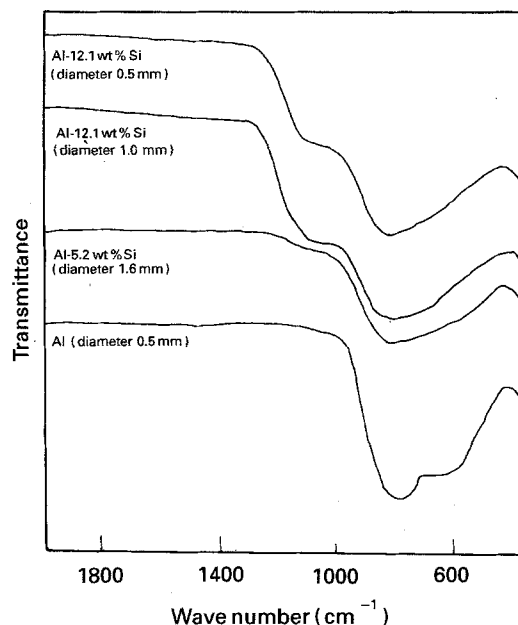

Figure 7 Infrared absorption spectra of alumina and alumina-silica powders prepared by wire explosion at the nearly equal energy ratio of about unity.

4.3. Change in the phases of the prepared powders with heating

The TG-DTA analysis, carried out in air at a heating rate of 10 K min^{-1} up to 1473 K , indicated that there was little gravimetric change in any powder. However, a small exothermic peak was observed in the temperature range $1153\text{--}1243\text{ K}$ in the case of the alumina-silica powders prepared by the Al-12.1 wt % Si wire explosion at charged voltages greater than 5.5 kV (diameter 1.0 mm) and 2.5 kV (diameter 0.5 mm). Mullite was identified in these powders after thermal analysis by XRD measurement.

Fig. 8 also shows IR absorption spectra of the powder produced by the Al-12.1 wt % Si (diameter 1.0 mm) wire explosion at 6.5 kV charged voltage, and after heating at 1123 , 1273 and 1473 K , respectively. The IR absorption peaks of the powder heated at 1273 K appeared at the wave numbers of 1150 , 900 , 820 , 750 and 550 cm^{-1} and those of the powder heated at 1473 K became clear, which were consistent with those of pure mullite crystal. Hence, it is suggested that the exothermic change is attributable to the formation of mullite, that is, an amorphous alumina-silica compound is expected to crystallize to mullite. It is generally known that there are two types of mullite formation process; the direct phase transformation of the amorphous state and the process where mullite is formed through γ -alumina (Al-Si spinel) [11]. In the present work, it seemed from the XRD data that silica was not dissolved in the γ -alumina phase because the diffraction angles of γ -alumina in the powders were in agreement with those of pure γ -alumina listed in the JCPDS card, even if the kind of wire and energy ratio were varied. Consequently, mullite might be transformed from the amorphous phase and not the γ -alumina phase in which silica was insoluble, though both γ -alumina and amorphous alumina-silica compound were formed when the wire was exploded. It

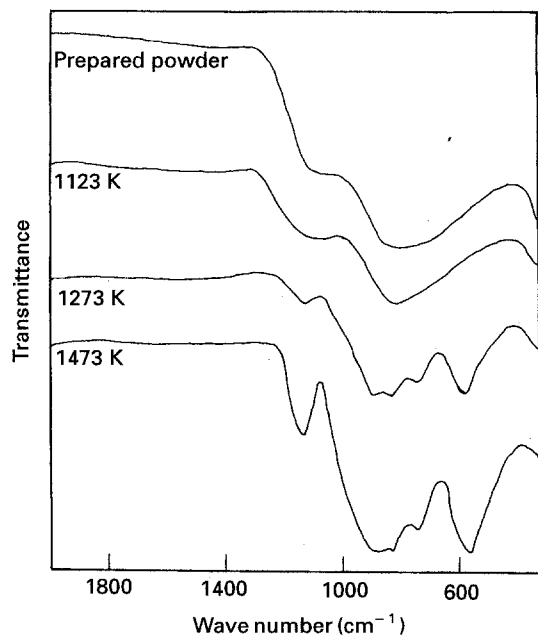

Figure 8 Change in the infrared absorption spectrum of the alumina-silica powder with heating. Wire, Al-12.1 wt % Si (diameter 1.0 mm); charged voltage, 6.5 kV.

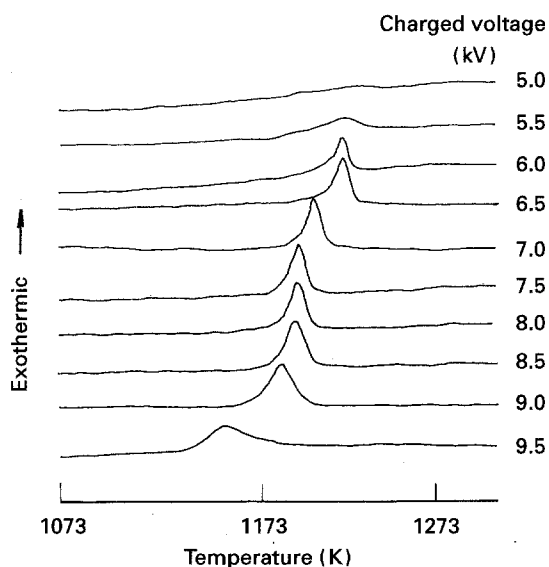

Figure 9 Effect of the charged voltage on the peak temperature of the exothermic change in the case of the alumina-silica powders produced from the Al-12.1 wt % Si (diameter 1.0 mm) wire.

was finally found that the prepared alumina powder was converted into α -alumina, and the prepared alumina-silica powders into α -alumina and mullite when they were heated up to 1473 K. Such mullite contains an excess of alumina as predicted from the chemical composition of the alloys.

For the alumina-silica powders obtained by the explosion of Al-12.1 wt % Si wire of 1.0 mm diameter, the effect of charged voltage on the peak temperature of exothermic change is shown in Fig. 9. It can be seen

from this figure that the peak temperature decreases from 1243 to 1153 K with an increase in the charged voltage. This supports the fact that the crystallization temperature decreases because of the decrement of particle size when the charged voltage, i.e. the energy ratio, becomes higher.

5. Conclusion

Aluminium and aluminium-silicon alloy wires containing 5.2 and 12.1 wt % Si were exploded in air by the electric discharge method. The powders formed were collected on filter paper using a vacuum cleaner, and their properties were examined. The results obtained may be summarized as follows.

1. The powders consist of large particles of several micrometres and very fine ones, which are formed from metallic droplets and vapours, respectively. The number of large particles decreases with an increase in the charged energy.

2. Although the particle-size distribution is broad, the average particle sizes are small and are increased from 0.7 μm to 1.3 μm with an increase in the energy ratio.

3. The mostly oxidized powders are identified as γ -alumina, amorphous alumina-silica compound and a small amount of the metal.

4. The amorphous phase crystallizes to mullite at temperature from 1153-1243 K, and the crystallization temperature falls with increase in the energy ratio, because the amount of fine particles formed from the vapours increases.

References

1. T. SUHARA, S. FUKUDA and H. ITO, *J. Jpn Thermal Spray Soc.* **5** (1968) 1.
2. T. SUHARA, S. FUKUDA, H. ITO and K. FUKUNAGA, *J. Jpn Soc. Tech. Plasticity* **11** (1970) 718.
3. K. KASE, H. ITO and Y. MIHASHI, *J. Jpn. Soc. Powder Powder Metall.* **16** (1970) 338.
4. *Idem, ibid.* **20** (1973) 67.
5. M. UMAKOSHI, H. ITO and A. KATO, *Yogyo-Kyokai-Shi* **95** (1987) 235.
6. T. SUHARA and S. FUKUDA, *J. Soc. Mater. Sci. Jpn* **24** (1975) 1003.
7. T. SUHARA, K. KITAJIMA, S. FUKUDA and H. ITO, *J. Jpn Inst. Metals* **39** (1975) 899.
8. O. KUBASCHEWSKI and C. B. ALCOCK, "Metallurgical Thermochemistry", 5th Edn (Pergamon Press, Oxford, 1979) p. 267.
9. M. UMAKOSHI, T. YOSHITOMI, H. ITO and A. KATO, in "Proceedings of the 1991 Annual Meeting of the Ceramic Society of Japan" edited by N. Mizutani (The Ceramic Society of Japan, Tokyo, 1991) p. 209.
10. T. YANAGASE and Y. SUGINOHARA, *Tetsu-to-Hagane* **57** (1971) 142.
11. K. OKADA, N. OTSUKA and J. KOSAKA, in "Mullite, Series of the Materials", edited by S. Somiya (Uchida Rokakuho, Tokyo, 1985) p. 13.

Received 31 January
and accepted 7 September 1994